



**INSTALLATION INSTRUCTIONS**  
**POLARIS RZR PRO XP**  
**REAR WINDSHIELD - VENT - TRR (Tool-less Rapid Release)**  
**PART # 78-4600-R**

**IMPORTANT NOTICES**

**READ AND UNDERSTAND THESE INSTRUCTIONS COMPLETELY BEFORE INSTALLATION TO AVOID INJURY TO YOURSELF, DAMAGE TO THE VEHICLE OR ACCESSORY.**

- For proper installation, **TWO** people are required.
- Torque specifications must be followed when tightening bolts. Over-tightening any and/or all screws will cause cracks around mounting holes which is not covered by any warranty.
  - As specified on carton label, once protective film on shields is removed, product cannot be returned.
- As specified on carton label, damage caused by packaging staples is not covered by warranty. All staples must be removed prior to removing product from carton.
- Failure to follow these installation instructions completely may void any warrantable components and result in product damage or personal injury.
- Do not use Loctite or any other similar fastener adhesive. These types of products react to plastics and cause cracking. Not covered by any warranty.
- Our windshields are made from the highest quality material providing optimum transparency and clarity. Blurriness and/or extrusion marks may or may not appear when looking through windshield from a wide, side-angle. This is normal for all extruded clear plastic materials.
- The application of improper cleaners, abrasive and/or dirty cleaning towels can severely damage the product. Failure to follow cleaning recommendation (provided herewith) may void any warrantable components.

**DEALER**

These instructions contain important information for future reference and must be given to the customer at time of purchase or upon completion of installation.

**Parts List** (parts available with kit only and not available separately)

ITEM	PART NAME	DESCRIPTION	QTY
A	Windshield	CNC windshield cut-out made of 1/8" thick GE polycarbonate or equivalent	1
B	Vent assembly	Includes: 1 vent cover, 1 vent flap assembly, 1 rubber vent seal and 7 vent mounting screws	1
C	Co-extruded bulb seal (1/4")	Includes: 45" Co-extruded bulb seal (1/4") / #77-95BS [end user to cut to exact length]	1
INSTRUCTION BAG	D	TRR clamp set (1 3/4")	1

**1. Installation**

- a) Find a clean flat area where you can safely lay down the windshield (Item A). Partially remove the protective film on both sides and apply the co-extruded bulb seal (Item C) to the lower lip using manual pressure to ensure it is properly and fully seated. Cut any excess.

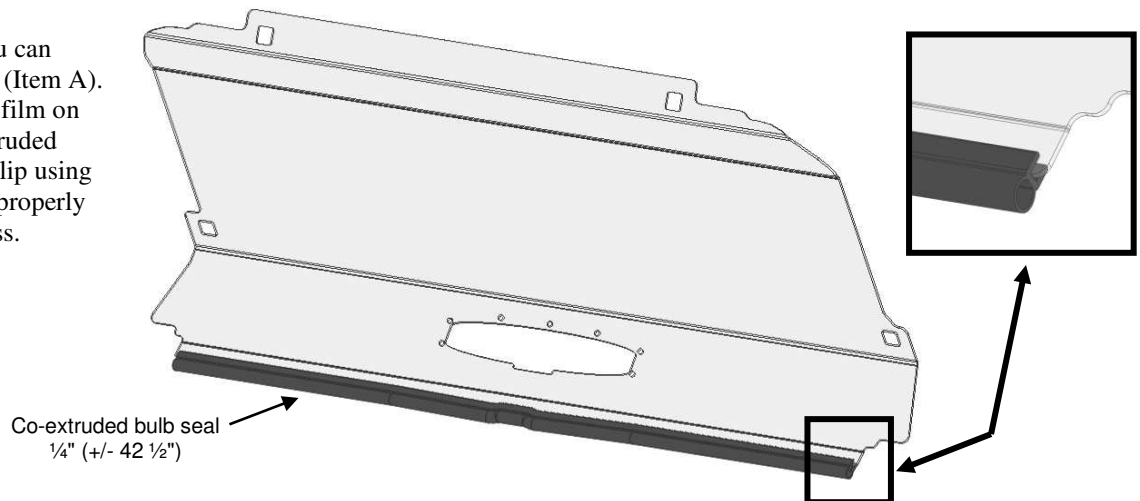

# IMPORTANT NOTICES

**Torque specifications must be followed when tightening bolts.**

**Over-tightening any and/or all screws will cause cracks around mounting holes which is not covered by any warranty.**

b) **Vent assembly (Item B) installation:** Partially remove the protective film on both sides of the windshield around the vent cutouts and follow instructions below.

1. From the front side (cab side) of the windshield, slide the vent flap assembly in the vent cut out as shown in image b1. Ensure the lower tab nests into the front of the windshield as shown in image b2 & b3.

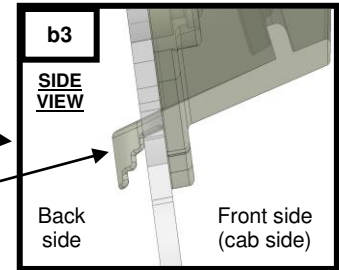
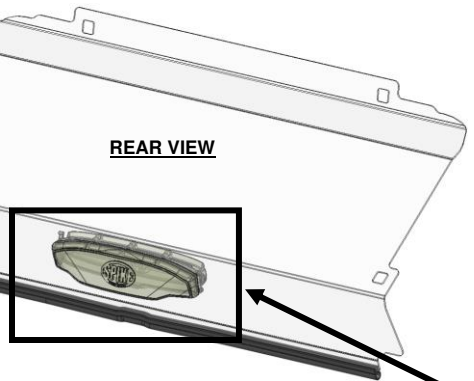
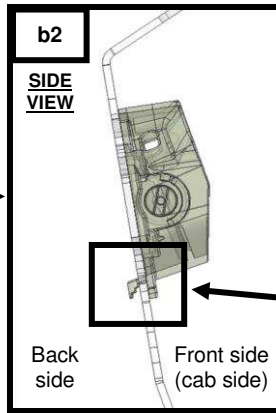
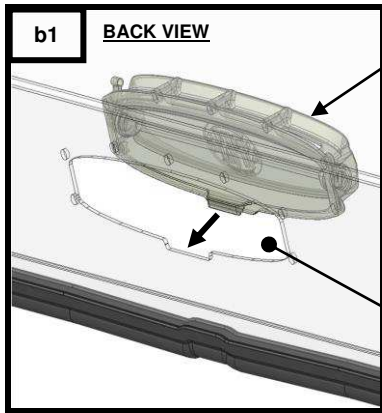

2. Install the remaining vent components (Item B) using supplied hardware as shown below in image b4 & b5.

**Caution: over tightening any hardware could cause irreversible damage to the windshield.**  
**DO NOT USE POWER TOOLS FOR THE INSTALLATION OF THE 7 MOUNTING SCREWS.**

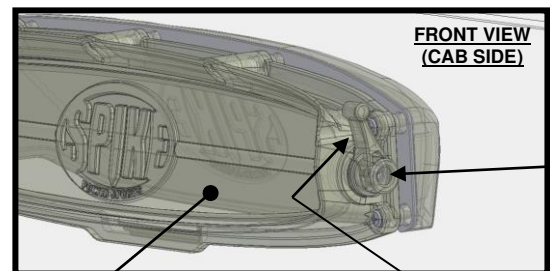
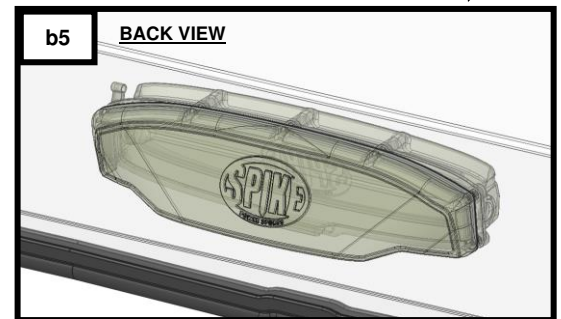
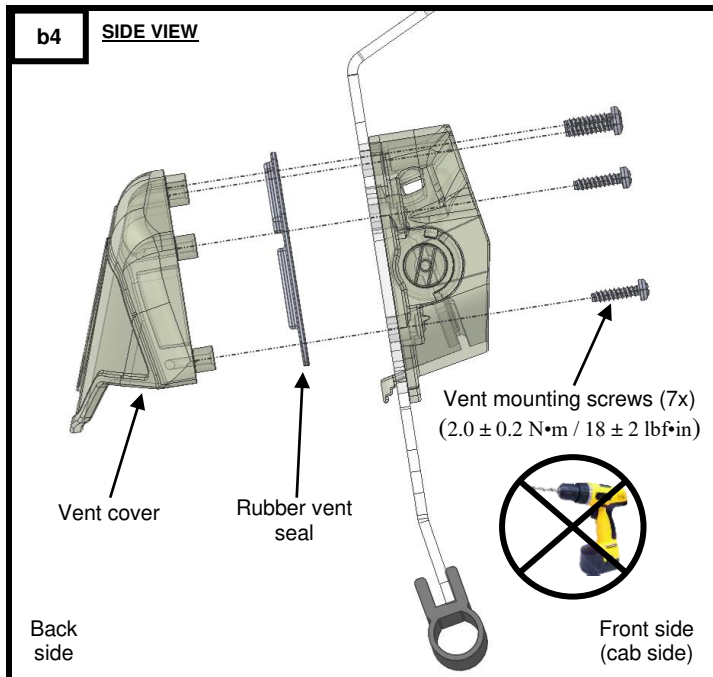

As shown on the front-view image, the **lever** is installed by default on the right side of the vent. Lever can be installed/relocated on left or right side of the vent. End user can decide.

Tightening/Loosening of the **screw** in the lever determines the force required for the **affle** adjustment.

- c) Slide and snap the TRR 1/8" shims (Items D) to the TRR windshield hooks (Items D) as shown below. These parts are designed as a tight-fit and require some force to properly snap together. When properly installed, they will not come off. See diagrams below for proper installation example.

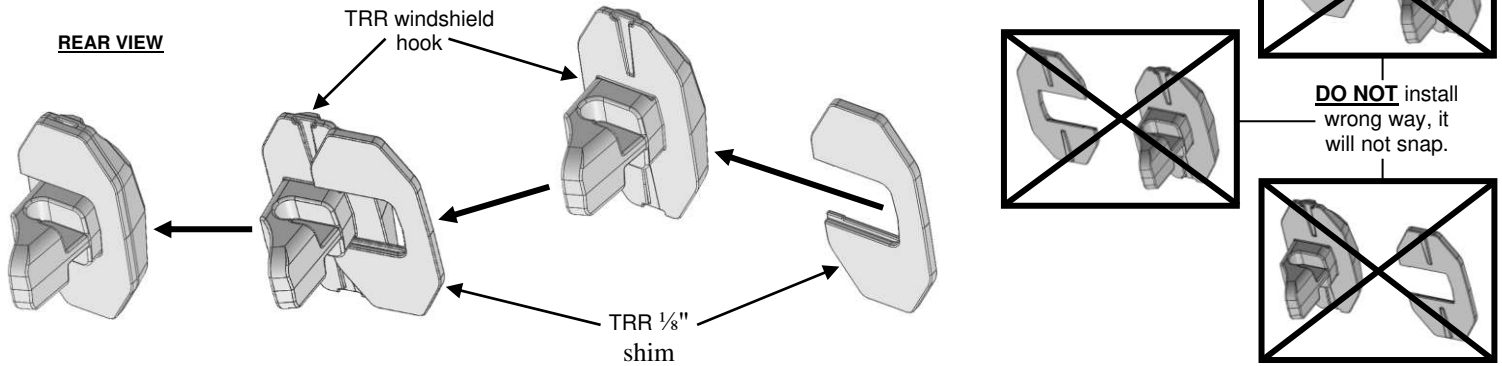

- d) Partially remove the protective film on both sides around the windshield square holes (4) and install the TRR clamps (Item D) on the windshield as shown below. (Right / Passenger side installation shown below)

- From the front side of the windshield (for the bottom mounting location only), slide the TRR windshield hook through the windshield square holes as shown in image c1. For the upper mounting locations, it's the same but from the back side of the windshield as shown on image c2.

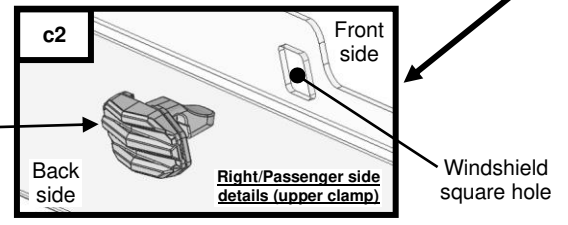
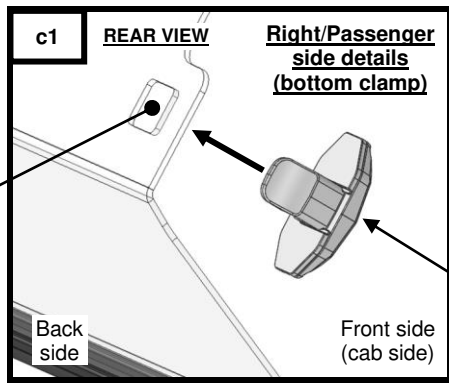
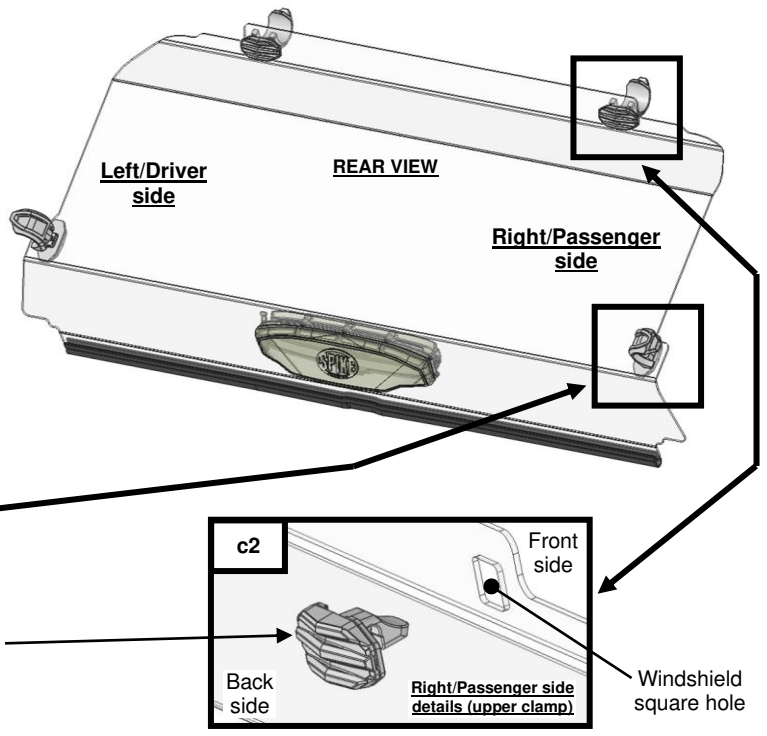

- From the back side, snap the TRR cage clamp to the TRR windshield hook as shown in image c3 & c4. These parts are designed as a tight-fit and require some force to properly snap together. When properly installed, they will not come off. See diagrams below for proper installation example. (Right / Passenger side bottom TRR clamps installation shown below)  
**TRR cage clamps should not come off easily during installation. If so, repeat this step until proper fit is achieved. They will not come off when properly installed.**

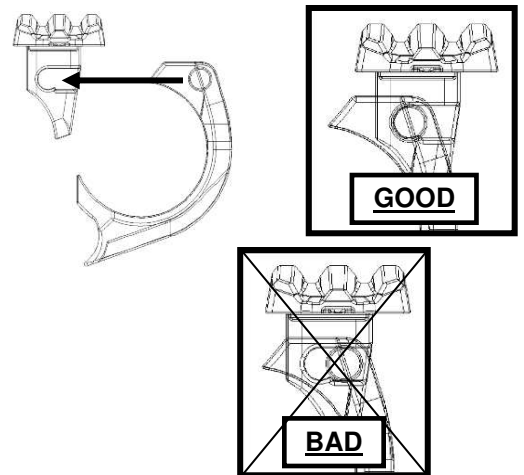
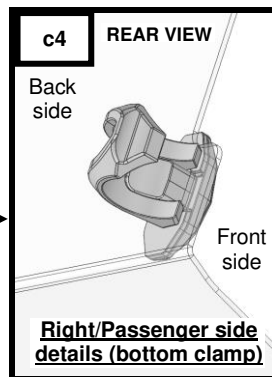
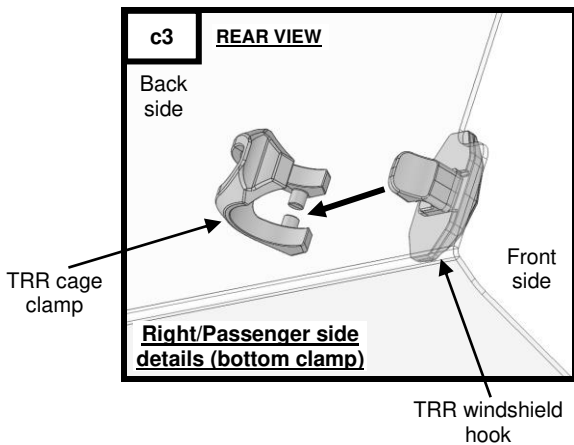

3. From the front side, press-fit the TRR SPIKE covers (Item D) to each TRR windshield hook as shown in image c5 & c6.

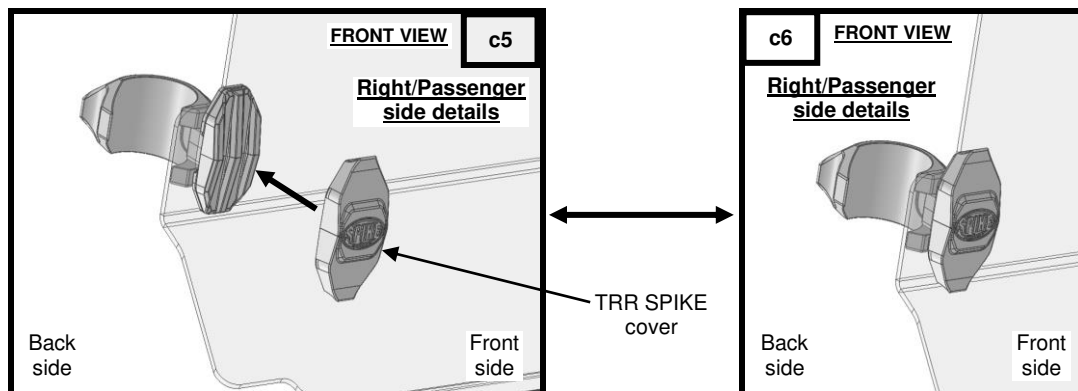

e) From the inside of the cab, install and secure the assembled windshield to the vehicle by rotating/snapping the TRR cage clamps to the vehicle roll bar cage as shown in images d1 & d2 & d3. Adequate force is required to rotate/snap the clamp to the roll bar.

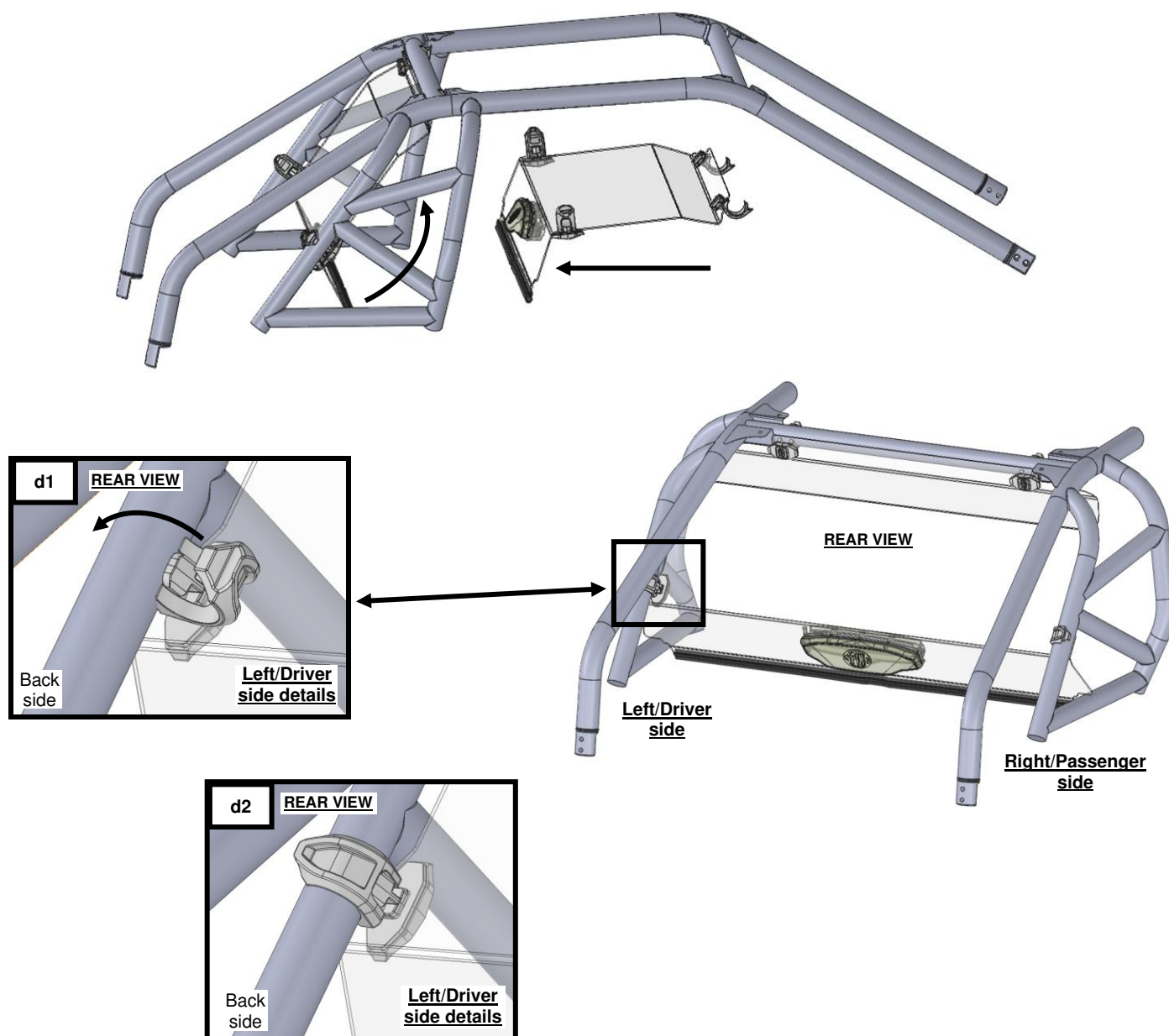

**FINAL**  
**ASSEMBLY**



**WARNING**

**TRR clamps must be properly installed. If not, the windshield will not be properly secured to the vehicle and may fly off when riding/towing. Serious injury may occur.**

**CAUTION**

**Please understand that open trailer towing can result in windshield/roof damage due to high wind pressure and road debris. Towing at Highway Speeds is NOT recommended. Spike suggests removal of roofs/windshields if towed in these conditions - removal will also create less drag on the tow vehicle. Limited Towing at lower speeds (60mph or less) for shorter distances is acceptable with a FULL Front Windshield AND Roof ONLY. If your rear windshield has a vent, we recommend it to be in the OPEN position. Towing with a half front windshield is NOT recommended.**

**CAUTION**

**NEVER trailer your vehicle oriented backwards with a full front, roof and rear windshields in place. Windshields/roof could break away.**

**ALWAYS trailer your vehicle facing forward.**



## 2. Maintenance and Care

Tighten all hardware after first use and periodically thereafter.

### CLEANING:

- Rinse with lukewarm water; wash gently with mild soap or detergent and lukewarm water, using a soft cloth or sponge. **DO NOT SCRUB** or use brushes or squeegees.
  - Rinse again. Dry with soft cloth or moist cellulose sponge to prevent water spotting.
- To remove wet paint, glazing compound or grease, rub lightly with a good grade of VM&P naphtha or isopropyl alcohol, then wash and rinse. **DO NOT USE GASOLINE.**

**NOTICE:** Abusive cleaning procedures by hand washing or automated washing equipment will eventually result in visual hazing, loss of light transmission and coating delamination.

#### Compatible Cleaning Agents

- Aqueous Solution of Soaps and Detergents

----- Joy ----- Freon T.F. ----- Palmolive liquid ----- Top Job ----- VM&P grade Naphtha ----- Windex (with ammonia D) -----

### MINIMIZING HAIRLINE SCRATCHES

For minimizing scratches and minor abrasions, mild automobile polish can be used.

**Recommended products:** Johnson Paste Wax, Novus Plastic Polish #1 and #2, Mirror Glaze plastic polish and Plexux1.

Testing polish on a separate Lexan sample is recommended. Be sure to follow product instructions carefully.